

# DEFINING RUGGED

EXCEPTIONAL ENGINEERING | ROCK SOLID | EXTENSIVE TESTING



## MCS VEHICLE SPECIFIC CONSOLE BOX WITH INTERNAL CUPHOLDER AND ARMREST: FORD UTILITY POLICE INTERCEPTOR (2012-2014)

| Placement                   | Seat Configuration | Drilling Required                         | Weight   | Lower Height (LH) | Overall Height | Width | Depth |
|-----------------------------|--------------------|-------------------------------------------|----------|-------------------|----------------|-------|-------|
| On top of transmission hump | Bucket             | <b>No</b> - attaches to transmission hump | 26.0 lbs | 6.2" to 8.5"      | 13.5"          | 9.2"  | 29.4" |

### Features:

- Heavy gauge steel, fully welded constructed for long-term durability
- Black powdercoat finish for maximum corrosion resistance
- Low profile no-drill vehicle specific console
- Vertical angled section accommodates 6" of mounting space
- Horizontal low profile section accommodates 7" of mounting space (without internal cupholder 11.5" of mounting space)
- 6 fasteners for mounting to transmission hump
- Removable top plate
- Removable center brace
- Fully welded construction for long term product life span
- Threaded pems provided for mounting armrest to the console
- 12 volt plug insert (located on passenger side)
- Computer can be mounted in an offset position on the smiley face pattern located on the top of the console (accommodates any Universal Display Bracket Mount or any Gamber-Johnson Motion Attachment ordered separately)
- Will ship fully assembled
- Includes armrest, internal cupholder, blank filler panels and faceplates
- Factory USB and Audio Jack must be relocated using Item No. 7160-0431, if you want to use them.

**Note: Does not require a leg kit or top plate, bolts directly to the vehicle**

Item No. **7160-0411**

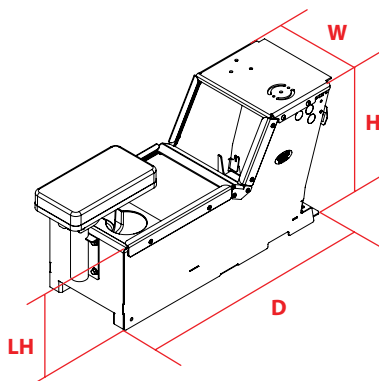

Very Well Connected™

3001 Borham Ave. | Stevens Point, WI 54481, USA  
 Phone: 715.344-3482 | Toll-free: 800.487-9220 | Fax: 715.344-5209  
 Email: [gamberj@gamberjohnson.com](mailto:gamberj@gamberjohnson.com) | Website: [www.gamberjohnson.com](http://www.gamberjohnson.com)

Follow us on:

This document, including images, may not be reproduced partly or fully without the expressed written consent of Gamber-Johnson's Marketing Department.  
 © Copyright 2012 Gamber-Johnson LLC